

MPC9610 - PRESSURE CONTROLLER



STANDARD

- 350ohm STRAIN GAGE INPUT
- AUTO / MANUAL CONTROL (BUMPLESS TRANSFER)
- FUZZY PID CONTROL OUTPUT
- SCALEABLE RANGE
- 2 CONFIGURABLE ALARMS HIGH/LOW/OFF
- AUTO or MANUAL CALIBRATION
- MANUAL ZERO
- LOCKOUT
- PROCESS VALUE - RETRANS
- FAST SAMPLING RATE - 100ms
- CONTROL RESPONSE TIME - 100ms
- AUTOMATIC RAMP-TO-SETPOINT
- OUTPUT RATE CHANGE LIMITER

TERMINAL CONFIGURATION

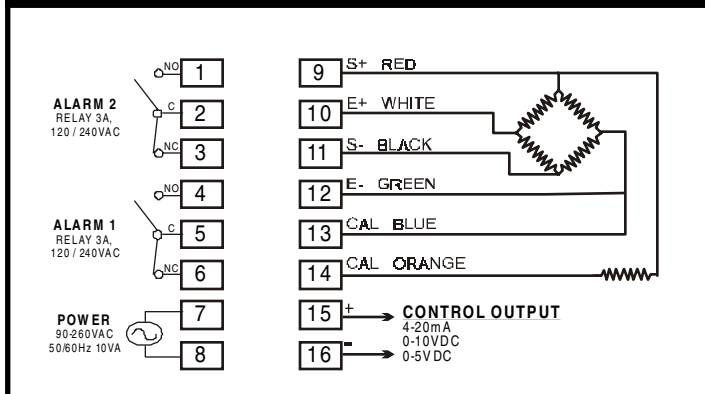

MODEL CODE

MPC9610- P - CONTROL OUTPUT

M	4-20mA
0	0-10mA
1	0-20mA
5	0-5VDC
6	1-5VDC
10	0-10VDC

SPECIFICATIONS - MPC9610

1. INPUT - PRESSURE TRANSDUCER

350ohm STRAIN GAUGE 2.00 - 4.00mV/V STANDARD - 3.3mV/V
 EXCITATION VOLTAGE 10VDC
 ACCURACY +/-0.5%
 SAMPLE RATE 100mS

2. CONTROL

Proportional Band 0.1-999.9 psi
 Rest (Integral) 0-999.9 Sec.
 Rate (Derivative) 0-999.9 Sec.
 Anti Rest Windup Inhibit integral action outside Proportion Band
 Ramp Rate 0-1000psi / minute.

3. OUTPUT

Current Isolated 0 (4) - 20 mA Max load 500 ohms.
 Linear Volts 1~5, 0~5, 0~10VDC. MAX 20mA

4. ALARM OUTPUTS

ALARM 1 5A/240VAC resistive
 ALARM 2 5A/240VAC resistive

5. POWER

Rating 85 - 265 VAC 50/60Hz 5VA max

6. ENVIRONMENTAL

Operating Temp -10 - 50C
 Humidity 0- 90%
 Insulation 20M ohms minimum @ 500VDC

7. PHYSICAL DIMENSIONS

MPC9610 96mmW x 96mmH x 100mmD
 MPC9610 Cutout 91mmW x 91mmH +/-0.5mm
 WEIGHT 300g