

RTDs - CONNECTOR-TYPE

RTD Assemblies

| Part No. | Style |
|----------|--|
| R500 | 350°F (177°C) max. Standard Male Connector. |
| R501 | 350°F (177°C) max. Standard Female Connector. |
| R502 | 1000°F (538°C) max. Standard Male Connector. |
| R503 | 1000°F (538°C) max. Standard Female Connector. |
| R504* | 350°F (177°C) max. Miniature Male Connector. |
| R505* | 350°F (177°C) max. Miniature Female Connector. |

*Available in 1/8" and 3/16" OD only.

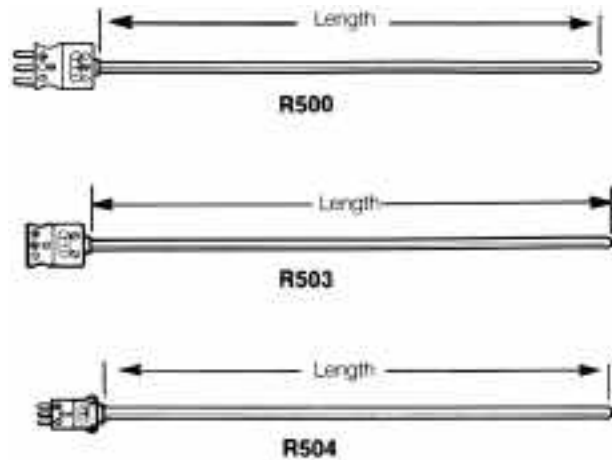

Ordering Information

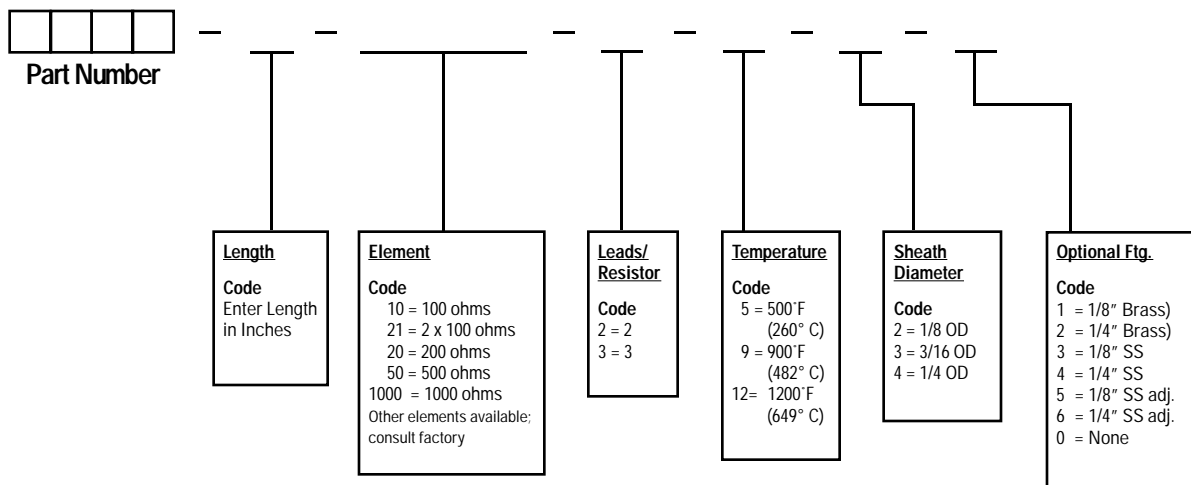

RTDs - HEAD-TYPE

RTD ASSEMBLIES

| Part No. | Style |
|----------|---|
| R100 | Gen. Purpose Cast Aluminum Head (4 wires max.) |
| R102 | Hazardous Location Cast Aluminum Head. |
| R103 | Screw Cover Thermoplastic Head. |
| R104 | Screw Cover Cast Iron Head. |
| R200 | Screw Cover Cast Aluminum Head. |
| R202 | Screw Cover Cast Aluminum Head with 1/2" NPT SS spring loaded oil and vapor seal. |
| R204* | Screw Cover Cast Aluminum Head with 1/2" NPT nipple spring loaded. |
| R205* | Screw Cover Cast Aluminum Head with 1/2" NPT nipples and union, spring loaded. |
| R300 | 300°F (149°C) max. Open Head (4 wires max.) |
| R400 | Bayonet Cover Mini-Head (4 wires max.) |
| R402 | Screw Cover Mini-Head (4 wires max.) |

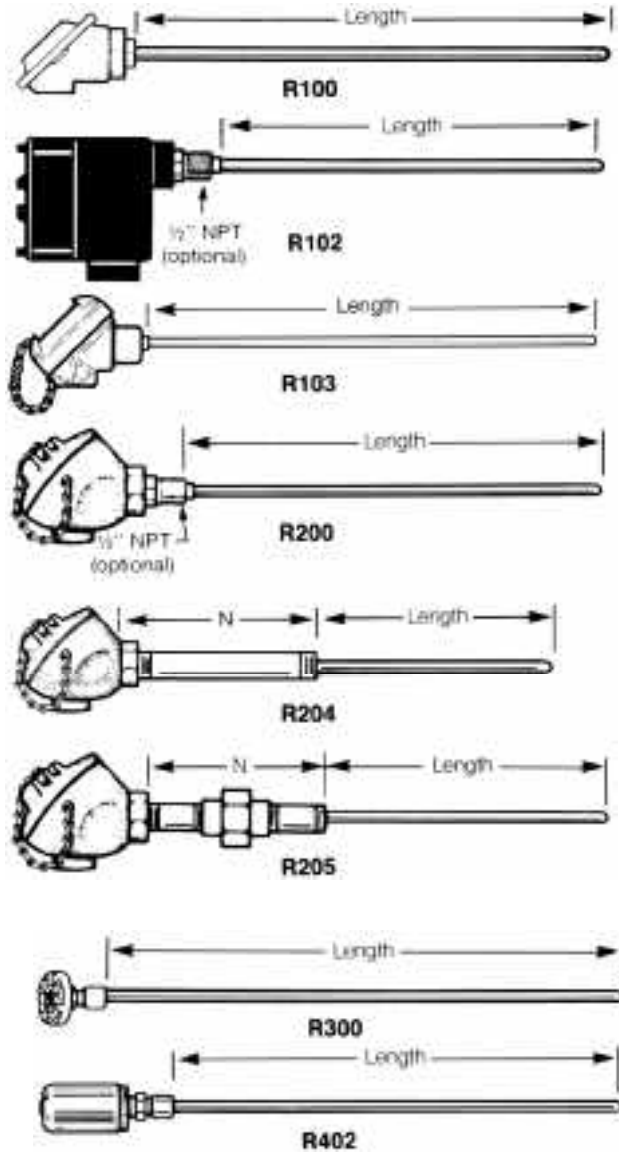

Ordering Information

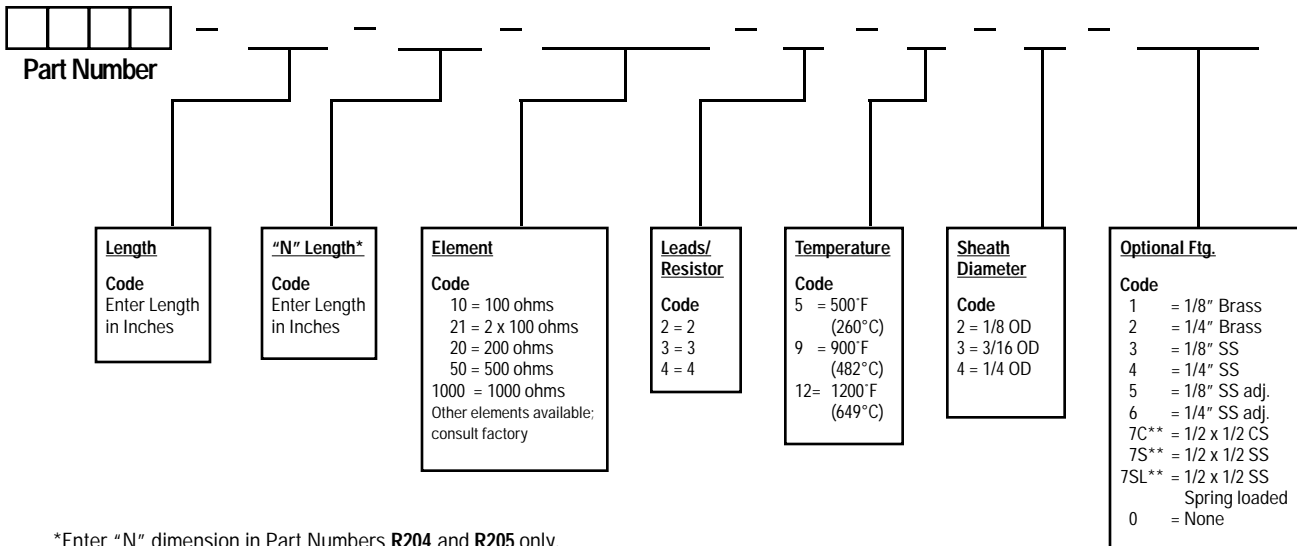

*Enter "N" dimension in Part Numbers R204 and R205 only.

**Only available on R100, R102, R103, R104 and R200 in 1/4" and 3/16" diameter.

RTDs - LEAD WIRE-TYPE

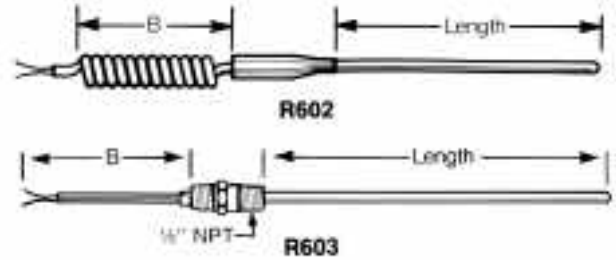
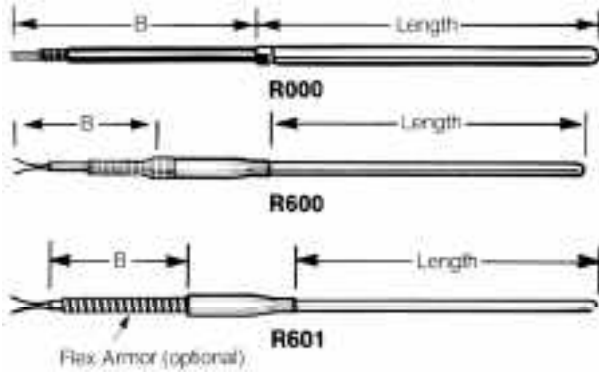

Ordering Information

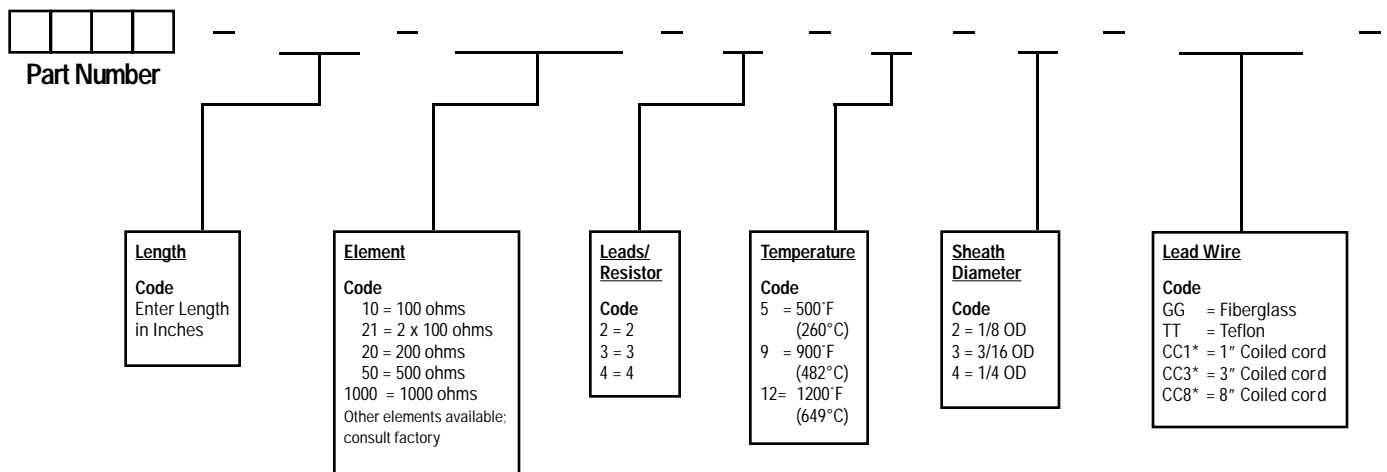

* Available on R602 only (Expands to approximately 5' per coiled foot).

** Omit "B" Length and Extension Cover on R602.

*** Available on R601, R603, R604, and R700 only.

RTDs - LEAD WIRE-TYPE

RTD ASSEMBLIES

| Part No. | Style |
|----------|---|
| R000 | Tube assembly with lead wires |
| R600 | Transition to lead wires with strain relief spring. |
| R601 | Transition to lead wires w/o strain relief spring. |
| R602** | Transition to polyurethane coiled cord. (3 wire only) |
| R603 | 1/2" NPT x 1/2" NPT stainless steel ftg. with lead wires. |
| R604 | 1/2" NPT x 1/2" NPT spring loaded SS ftg. with lead wires (1/4 & 3/16 dia. only). |
| R700 | 1/2" NPT x 1/2" NPT carbon steel fitting with lead wires. |

